

# Mirrors at the Front Entrance

Is the Way You're  
Hanging Your Mirror  
at the Front Door  
Making You Poor?!

**When Feng Shui was first introduced to the western world it was described as the aspirin of Feng Shui... That was of course until they discovered it was really the antibiotics!!!**

Mirrors at the front door can look really great, they can expand the chi at the front door which is great for small poky entrances and when they attract the right energy into the home they can have really good effects.. The truth is, mirrors do more than cure a headache or fix the flu in Feng Shui... Mirrors can be used to attract, deflect, repel, absorb, re-direct, extend.. Not only do they expand the chi in a building, they can also bounce good chi out of a building if positioned wrongly. Probably one of the most important things to know about mirrors is that they do interact with the [unseen energies in a building](#) and this may have a very good effect or a not so good effect... Therefore its important to know there is no generic recipe for using mirrors in Feng Shui (so if the mirror doesn't feel right or there weren't good results after installing it—take it down and use a picture instead!).

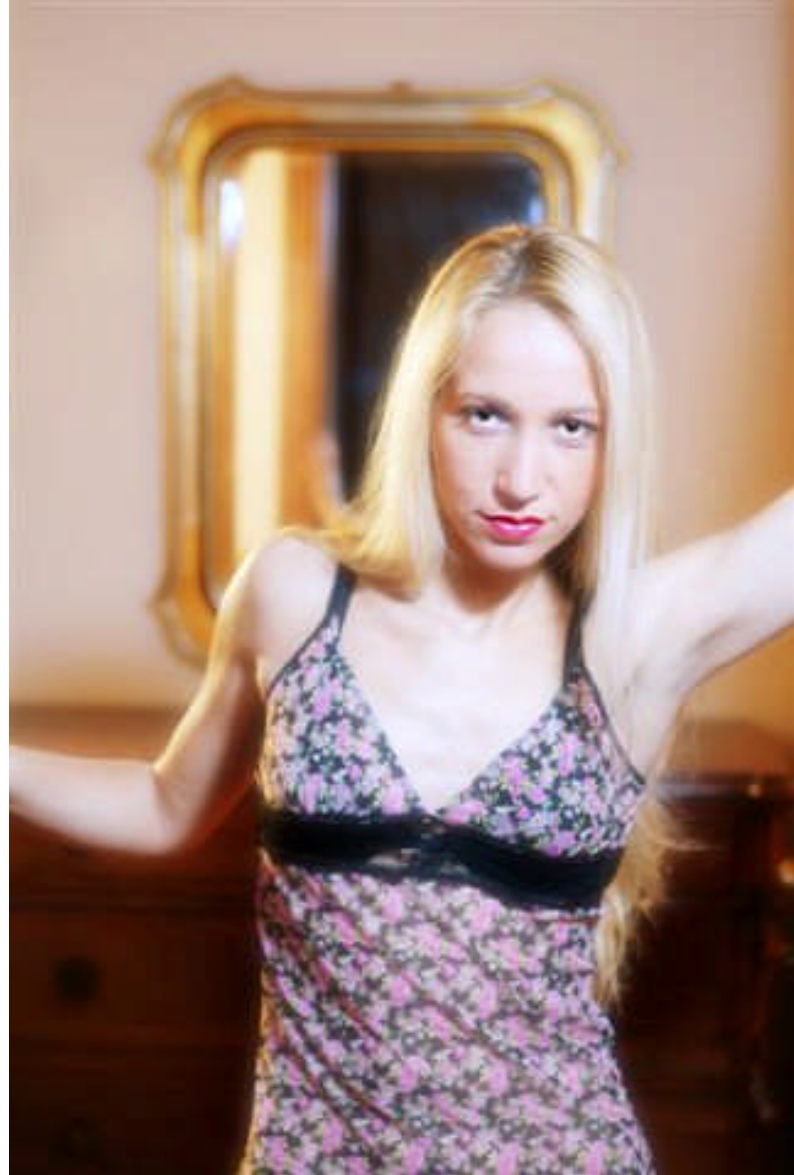

*If the mirror doesn't feel right  
or there weren't good results  
after installing it—take it down  
and use a picture instead!*

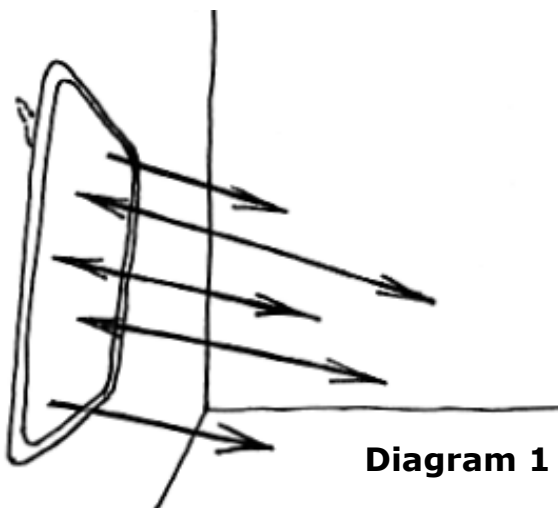

**Diagram 1**

## **Diagram 1**

The best way to hang mirrors is when you can hang a mirror so that it tilts out from the top. By letting the mirror tilt out from the top you can *draw in* the energy that's opposite. You just need to make sure it tilts out enough (say 5cm or 2 inches)

A mirror that tilts out from the top has the capacity to draw the good energy into the room or area. Be aware that mirrors can also draw in negative unseen energies so you don't want to bring every view into your home.

# Mirrors at the Front Entrance

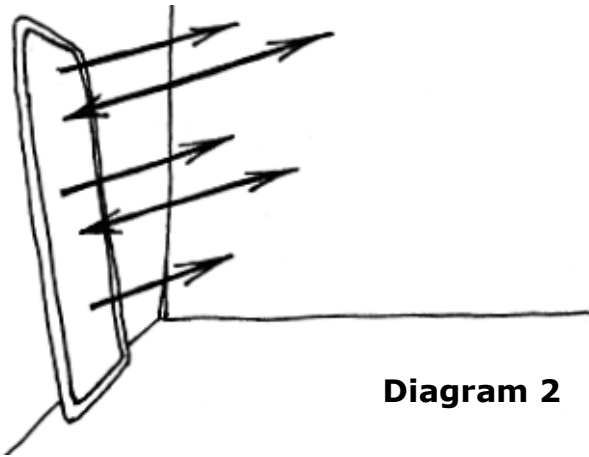

Diagram 2

## Diagram 3

This diagram shows a mirror that is installed flat on the wall. In this configuration, the mirror is either glued onto the wall or bolted onto the wall in a way that the mirror is evenly placed on the wall. This mirror position has the potential to bounce the good energy away because it re-directs the energy immediately back towards the direction it came from (potentially not good). If you have this configuration at your front door and you don't have good things going on in life (and you live in a rental home where you cannot change the mirror) you may need to consider installing one of the following remedies...

## How to Remedy a Flat Installed Mirror

The flat installation of mirrors (diagram 3) can create a situation where the mirror bounces energy out the front door. Note: this is good if the energies are negative and bad if the energies are favourable.

### Remedies are as follows:

1. Add a sheer curtain over the mirror (hang the curtain in a decorative way) and create a fab lighting effect to highlight the mirror and draw the attention back into the home.
2. Hang a number of crystals or other pretty items down over the front of the mirror to diffuse energies and prevent them from going straight out the door!
3. Cover the mirror completely by adding a painting over the top or a decorative wall hanging
4. Add a set of low hanging light fittings to reflect in the mirror and create a barrier between the front door and the mirror...

## Diagram 2

This mirror is arranged so that it is tilting outwards from the floor. So the mirror sits on the floor and leans back against a wall. From a Feng Shui point of view—this mirror disperses the good energy and does not allow it to enter a room. Before the good Ch'i can enter the mirror has already bounced it away/backwards (potentially not good).

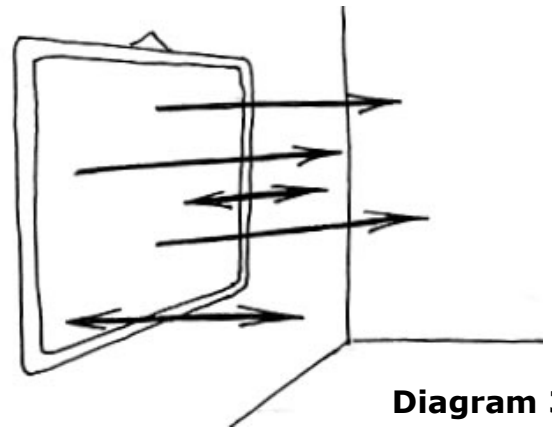

Diagram 3

## Mirror FAQ's continued...

A: If you know you have prosperity influences opposite your front door and you install it as per diagram 1, then yes, its brilliant to have a mirror opposite your front door.

Q. Can a mirror opposite my front door make me poor?

A: Yes, flat installed mirrors opposite the front door can make you poor if your prosperity influences are also at your front door (because it bounces them away). There are two prosperity influences in any building so we have to take care of these very carefully.

**When you install mirrors and they are in the "right place" it should bring a good feeling into the room. If you suspect a mirror isn't good where it is, never hesitate to remove it and put it somewhere else...©**

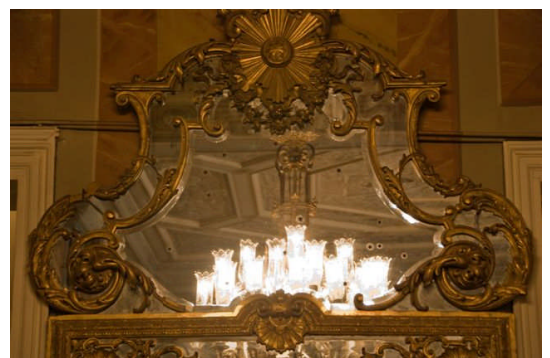

Picture by [Lindom](#) (Dreamstime.com)

## Mirror FAQ's

Q: Is it good to have a mirror opposite the front door?